

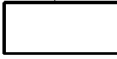
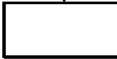
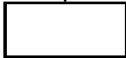
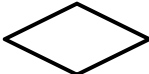

Prosedur

APEL PAGI PNS

DINAS KESEHATAN KABUPATEN LIMA PULUH KOTA

No.	Kegiatan	Pelaksana			Mutu Baku			Keterangan
		Staf	Kasi/Kasubbag	Kabid /Ka. Dinas	Kelengkapan	Waktu	Output	
1	2	3	4	5	6	7	8	9
1	Membunyikan Bel jam : 07.30 wib				Bel	15 detik	Bunyi Bel terdengar di semua ruangan	
2	Berbaris dilapangan apel sesuai Bidang masing-masing				Seluruh Pegawai Dinkes	1 - 2 menit	-	
3	Komandan Apel menyiapkan barisan				-	2 - 3 menit	-	
4	Pembina Apel memulai Apel				Wire Less	-	-	
5	Amanat Apel				Wire Less	15 menit	Informasi	
6	Berdo'a				-	5 menit	-	
7	Barisan dibubarkan komandan Apel				-	30 detik	-	

Keterangan gambar :



Mulai atau berakhirnya kegiatan

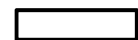

Kegiatan



Menandakan adanya pengambilan keputusan (Ya/Tidak)

**Kepala Dinas Kesehatan
Kabupaten Lima Puluh Kota**

dr. Adel Nofiarman
Nip. 19650914 199803 1 002